

## AKASISON RAIL BRACKETS 40-315 MM

ARTICLE NUMBER: 75 XX 35

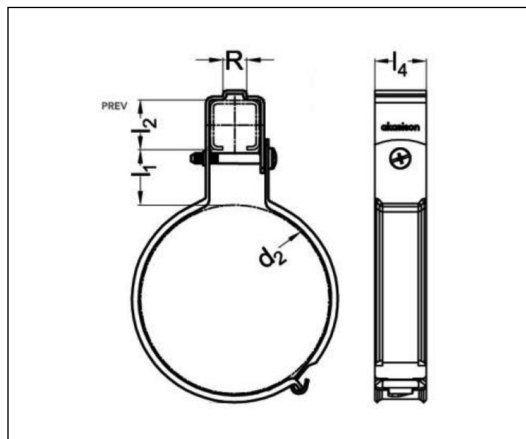

Hook and close part: Steel 4.6DD12 (EN10111)  
Zink 13 um

Anti-loss: NR / SBR  
No CE marking applies to a fixing system\*

d (mm)	Art. Nr.	d <sub>2</sub> (mm)**	l <sub>1</sub> (mm)	l <sub>2</sub> (mm)	l <sub>4</sub> (mm)	R	Weight (kg)	Bolt	Hook part (mm)	Close part (mm)	FN <sub>z</sub> (N)
40	75 04 35	42	35	30	30	M10	0,144	M6x45	30 x 2	30 x 1.5	2500
50	75 05 35	52	35	30	30	M10	0,157	M6x45	30 x 2	30 x 1.5	2500
56	75 56 35	58	35	30	30	M10	0,164	M6x45	30 x 2	30 x 1.5	2500
63	75 06 35	65	35	30	30	M10	0,173	M6x45	30 x 2	30 x 1.5	2500
75	75 07 35	77	35	30	30	M10	0,189	M6x45	30 x 2	30 x 1.5	2500
90	75 09 35	92	35	30	30	M10	0,209	M6x45	30 x 2	30 x 1.5	2500
110	75 11 35	112	35	30	30	M10	0,235	M6x45	30 x 2	30 x 1.5	2500
125	75 12 35	127	35	30	30	M10	0,255	M6x45	30 x 2	30 x 1.5	2500
160	75 16 35	162	35	30	30	M10	0,301	M6x45	30 x 2	30 x 1.5	2500
200	75 20 35	202	35	30	30	M10	0,585	M8x50	30 x 3	30 x 3	3500
250	75 25 35	252	35	41	40	M10	0,97	M8x60	40 x 3	40 x 3	5000
315	75 31 35	317	35	41	40	M10	1,381	M8x60	40 x 4	40 x 3	8000

\* Brackets and fixing systems for plastic pipe system are not covered by harmonised European Standards

\*\* Assembled dimension with tolerance